

# Free Spinning Bearings Inserts



PH: (800) 882-8642 • FAX: (847) 759-0630  
www.amibearings.com

## “FS” Standard Features

- Set Screw (SER) or Accu-Loc® (SUE)
- Inch and Metric Bore Sizes
- Bore Sizes: 1/2" to 2-7/16" (20mm to 40mm)
- Custom Seal and Lubrication Combinations
- Steel Cage
- 52100 Chrome Steel
- Zone Hardened Wide Inner Race
- Low Drag/Non Contact Seal

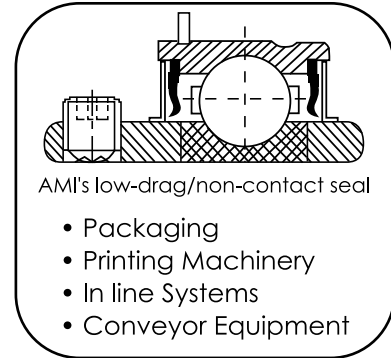

## “FSX” Standard Features

- Zone Hardened Wide Inner Race
- Low Drag/Non Contact Seal
- Reinforced, Stabilized Nylon Cage
- 120° Recessed Point Set Screw Locking
- Oil Lubrication

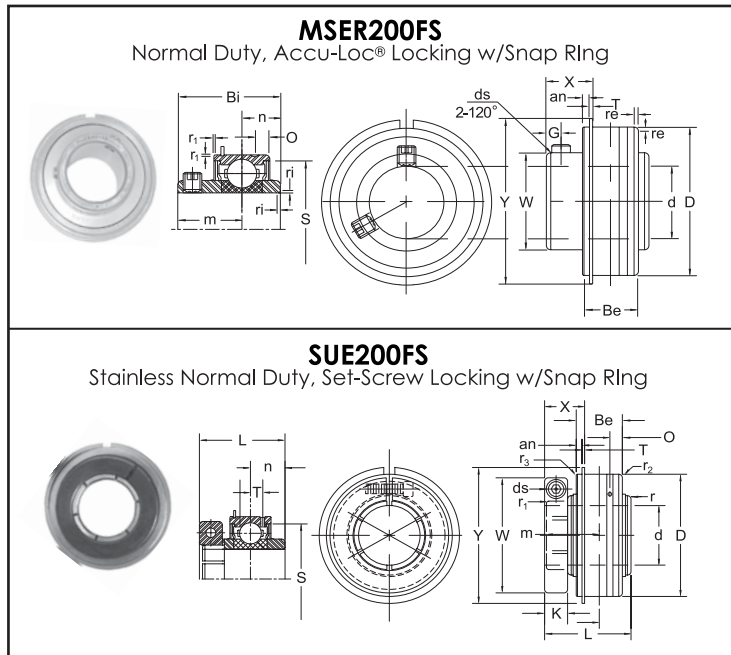

STARTING TORQUE CHART			
FREE SPIN SERIES (FS)/(FSX)			
AMI SER/SUE "FS"	Starting Torque (gf•cm)		
	Avg	Max	Min
201 - 204	30	45	25
205	40	60	30
206	60	90	45
207	80	120	60
208	100	150	75
209	120	180	90
210	140	200	105
211	160	210	120
212	180	230	135



Interchange by Manufacturer			
Bore	AMI	MB	SealMaster
1 (in.)	SUE 205-16FS/FSX	ER-16MKFF	ER-16T XLO
25 (mm)	SUE 205FS/FSX	—	ER-205T XLO

