

Shur-Seal

Bearing Protection System

AMI Bearings, Inc.
an **ASAHI** company

PH: (800) 882-8642 • FAX: (847) 759-0630
www.amibearings.com

The Shur-Seal Bearing Protection System stands up to repeated high-pressure washdown and the steady stream of dry and fine particle contaminants that surround mounted bearings in many of today's plant environments.

Spring-Loaded Back Seal that Sits Flush with the Back of the Housing for 2-Bolt, 3-Bolt & 4-Bolt Flange Housing Styles

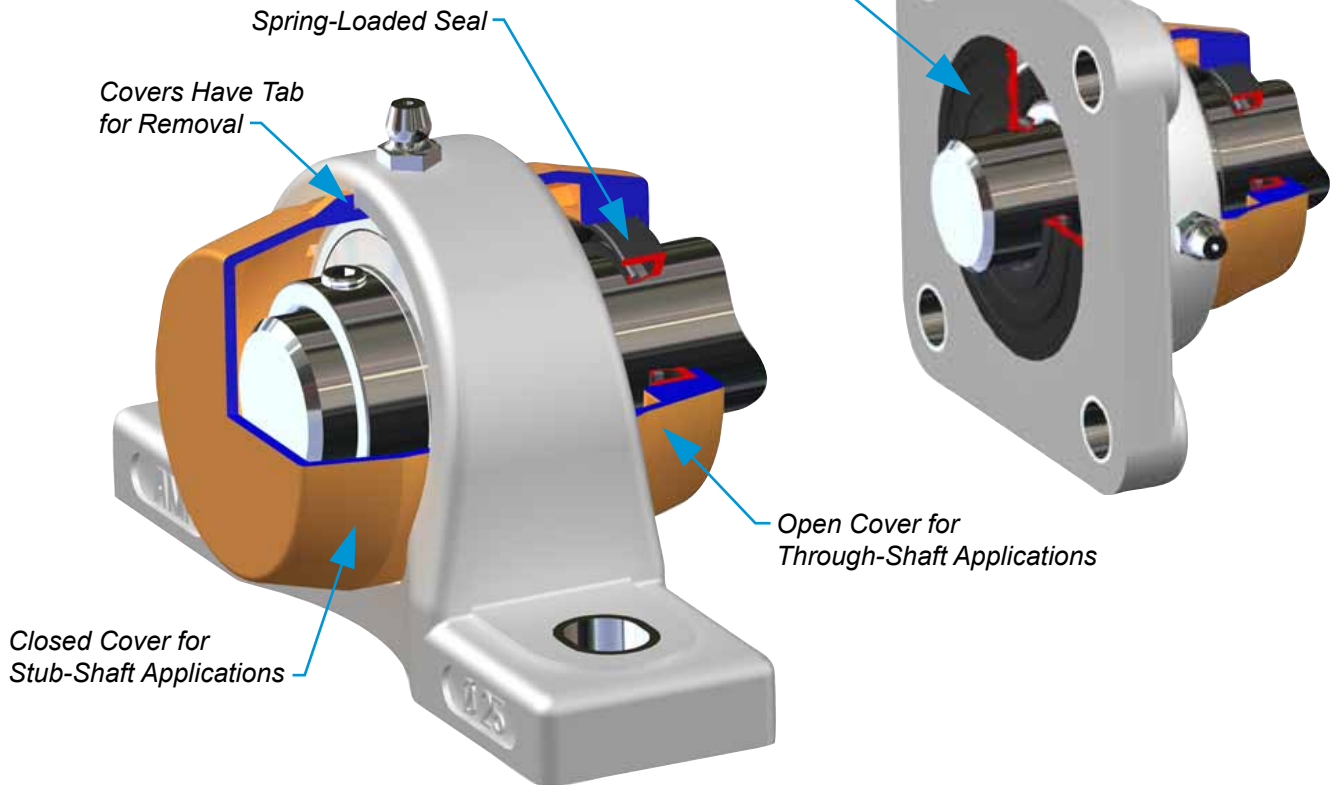

OPEN COVERS		
BORE	UNIT #	LIST
1/2	204-8OC*	9.80
3/4	204-12OC*	9.80
7/8	205-14OC*	11.70
15/16	205-15OC*	11.70
1	205-16OC*	11.70
1-1/8	206-18OC*	13.30
1-3/16	206-19OC*	13.30
1-1/4	206-20OC*	13.30
1-1/4	207-20OC*	15.50
1-3/8	207-22OC*	15.50
1-7/16	207-23OC*	15.50
1-1/2	208-24OC*	17.10
20	204OC*	9.80
25	205OC*	11.70
30	206OC*	13.30
35	207OC*	15.50
40	208OC*	17.10
45	209OC*	19.80
50	210OC*	22.40

CLOSED COVERS	
UNIT #	LIST
204CC*	5.20
205CC*	5.80
206CC*	6.50
207CC*	7.10
208CC*	8.20
209CC*	9.70
210CC*	11.20

BACK SEALS		
BORE	UNIT #	LIST
3/4	204BS-12	5.30
7/8	205BS-14	5.80
15/16	205BS-15	5.80
1	205BS-16	5.80
1-1/8	206BS-18	7.90
1-3/16	206BS-19	7.90
1-1/4	206BS-20	7.90
1-1/4	207BS-20	8.40
1-3/8	207BS-22	8.40
1-7/16	207BS-23	8.40
1-1/2	208BS-24	9.50
20	204BS	7.40
25	205BS	9.60
30	206BS	11.40
35	207BS	14.30
40	208BS	16.60

Seals Out Contaminants
Retains Lubrication
Ideal for HACCP Monitored Facilities

The Shur-Seal system is comprised of any combination of Closed Covers, Open Covers, and Back Seals that integrate with our Thermoplastic Bearing Housings

MUCPPL205-16CW

White Housing Material
(Change "W" to "B" for Black)

2 Open Covers
(Change to "CE" for 1 Open & 1 Closed Cover)

C = 2 Open Covers
CE = 1 Closed & 1 Open Cover
W = White Housing
B = Black Housing
OCW = White Cover
OCB = Black Cover
OCO = Orange Cover
BS = Back Seal

NOTE: For 2-Bolt, 3-Bolt and 4-Bolt Flange: 1 Open Cover and Back Seal

*For Open & Closed Covers please specify one of the following suffixes after the part number: "W" for white cover, "B" for black cover, or "O" for orange cover (Example: 205-16OCW = white open cover)

Shur-Seal

AMI Bearings, Inc.
an **ASAHI** company

PH: (800) 882-8642 • FAX: (847) 759-0630
www.amibearings.com

The three-part system that seals out contaminants and seals in lubricants. Ideal for HACCP monitored facilities; Food Processing, Wastewater Treatment, Packaging & Material Handling, Wood, Paper, Pulp and Gypsum & Particle Board

- 1. High Quality Thermoplastic Mounted Bearing** - Including a unique sealing system to completely encase the bearing and eliminate downtime associated with peeling, chipping, or flaking of the housing. Available with Stainless Steel, Zinc, or Kanigen inserts.
- 2. Closed or Open End Caps** - Ideal for flexible mounting. Available in highly-visible OSHA orange, white or black.
- 3. Spring-Loaded Back Seal** - Once put into service it will fit snugly in the housing for the life of the unit.

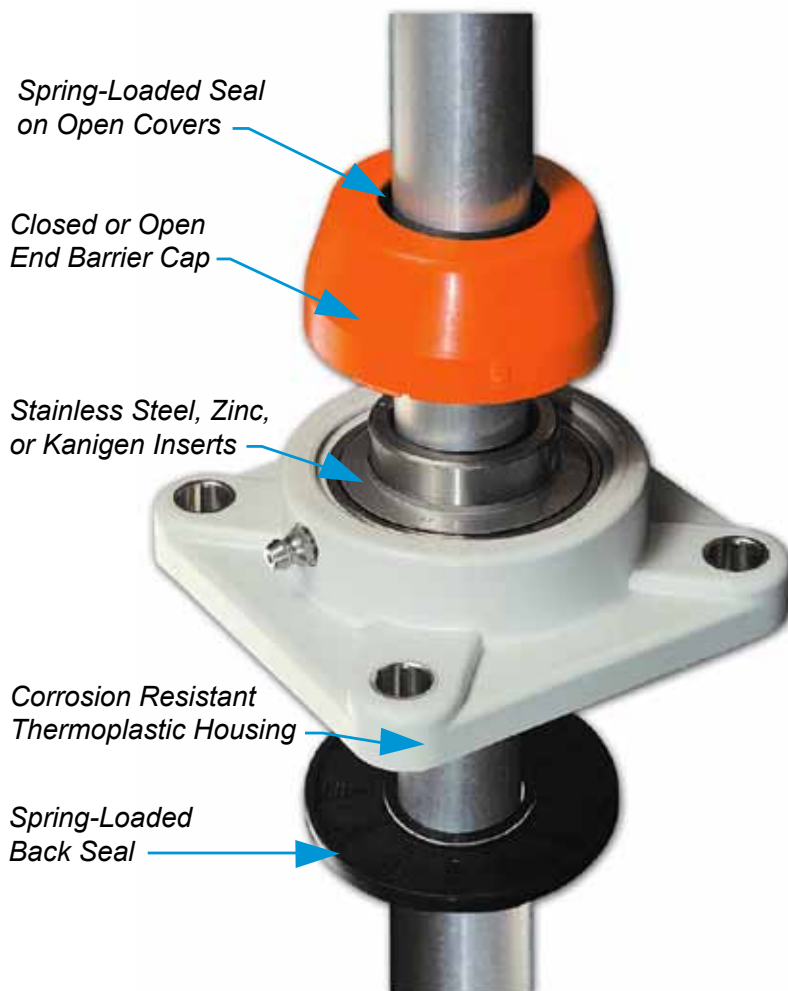

Pillow Block with Covers

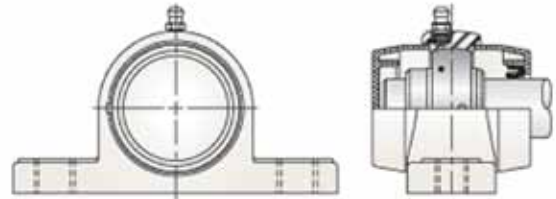

Tapped Base Pillow Block with Covers

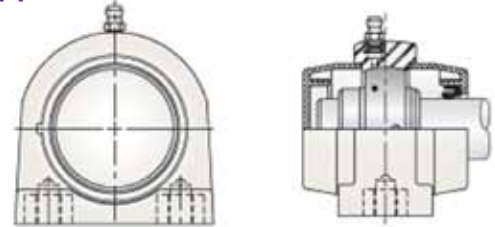

2-Bolt Flange with Cover & Back Seal

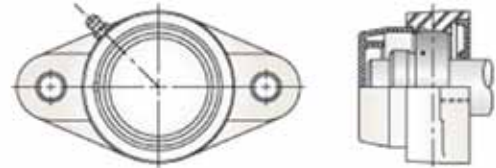

3-Bolt Flange with Cover & Back Seal

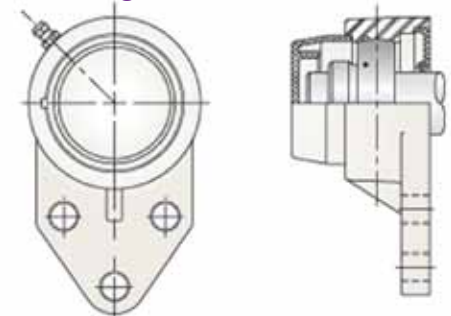

4-Bolt Flange with Cover & Back Seal

